



# DAB Pump<sub>s</sub>BOOSTER SILENT

## ON/OFF AUTOMATIC ELECTRONIC BOOSTER SYSTEMS



Tel. 021-5367-4785  
 Phone. 0815-8630-0000  
 hargapompa@gmail.com  
 www.magpompa.com



### DOMESTIC WATER SUPPLY

The world's quietest (67 dB) multi-impeller (3-4-5) self-priming pumps, with integral electronics for water supplies in homes and gardens.

Equipped with an electronic safety device to prevent dry running.  
 Integral check valve on suction.

Automatic Starting and Stopping when tap is turned on or turned off.  
 Manual and automatic reset

**Supplied complete with power cable and plug.  
 Supplied with 2 l tank.**



## TECHNICAL DATA

MODEL	CODE	N° IMPELLER	ELECTRICAL DATA				
			VOLTAGE 50 Hz	P1 MAX KW	P2 NOMINAL		In A
					kw	HP	
<b>BOOSTER SILENT 3 M</b>	60122696	3	1 x 230 V ~	0,8	0,55	0,75	3,7
<b>BOOSTERSILENT 3 M 1,5 BAR</b>	60141493	3	1 x 230 V ~	0.8	0,55	0,5	3,7
<b>BOOSTER SILENT 4 M</b>	60122698	4	1 x 230 V ~	1	0,75	1	4,7
<b>BOOSTER SILENT 5 M</b>	60122699	5	1 x 230 V ~	1,25	1	1,36	5,7

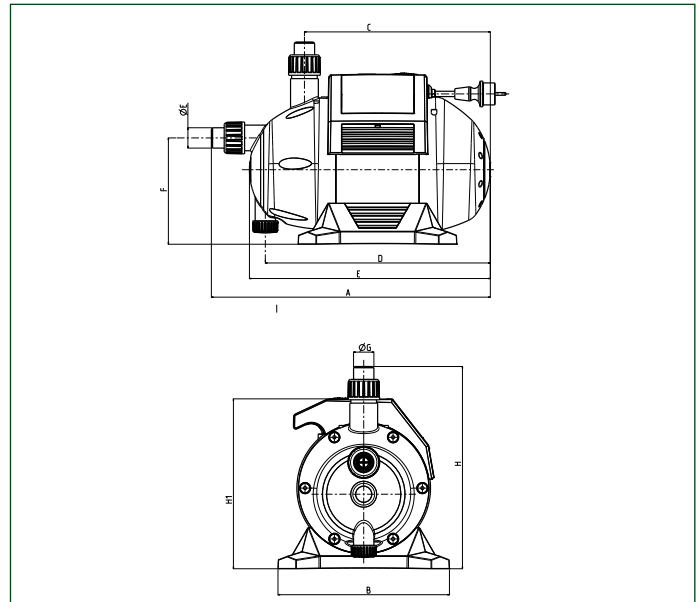
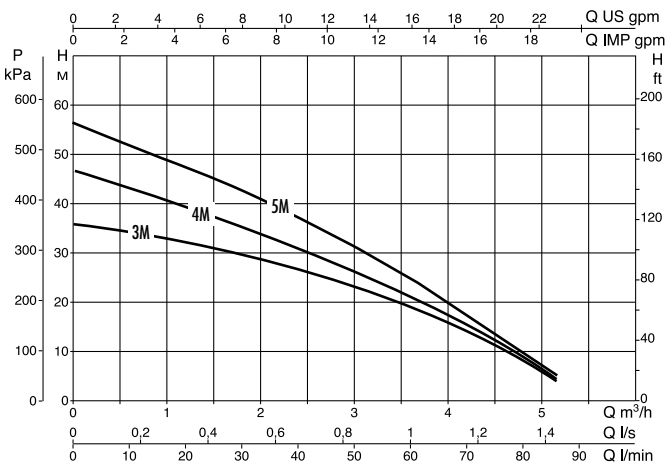

MODEL	A	B	C	D	E	F	ØG	H	H1	PACKAGING DIMENSIONS			WEIGHT Kg	Q.TY x PALLET
										L/A	L/B	H		
<b>BOOSTER SILENT 3 M</b>	455	280	305	370	395	175	33	330	280	480	300	470	11,5	18
<b>BOOSTER SILENT 3 M 5 bar</b>	455	280	305	370	395	175	33	330	280	480	300	470	11,5	18
<b>BOOSTER SILENT 4 M</b>	455	280	305	370	395	175	33	330	280	480	300	470	11,5	18
<b>BOOSTER SILENT 5 M</b>	455	280	305	370	395	175	33	330	280	480	300	470	11,5	18