



NOWA®

VORTEX PUMPS

Segmental type, self-priming

Made by Germany Technique

25HV...32HV.

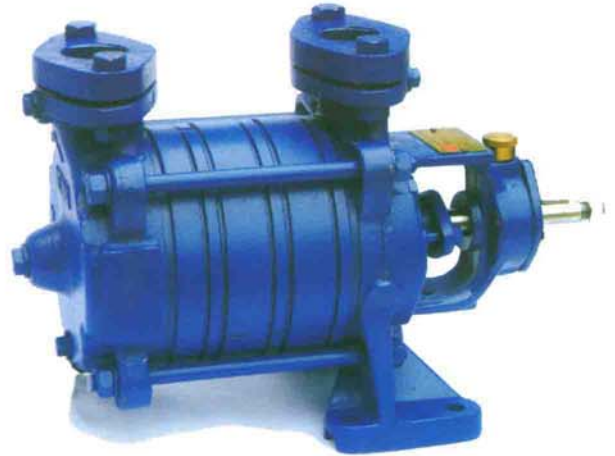
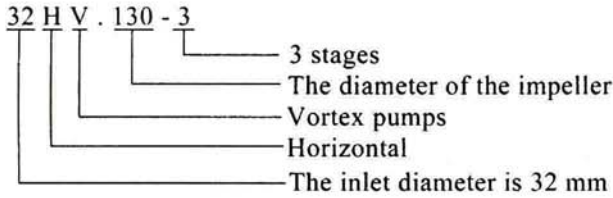

Description

NOWA vortex pumps are horizontal, multistage, self-priming pumps. They are suitable for handling pure and turbid liquids without any abrasives. They can handle gas during normal liquid duty. The pumps are normally driven by electric motors. Other drives are permissible except belt-drive.

Application

NOWA vortex pumps are used:

in all branches of trade and industry – for boosting pressures, for providing cooling water, for circulating water, for feeding boilers, for conveying condensate and for running mix or cleaning plants:

in domestic plants and agriculture – handling water for irrigation, drainage and sprinkling.

Technical Data

Capacity:	Max. 4.5 m ³ /h
Head:	Max. 98 m
Speed:	Max. 1800 rpm
Temperature:	Max. 120 °C
Casing pressure:	PN 10
Shaft sealing:	Stuffing box
Direction of rotation:	Clockwise when looking at the pump from the drive end

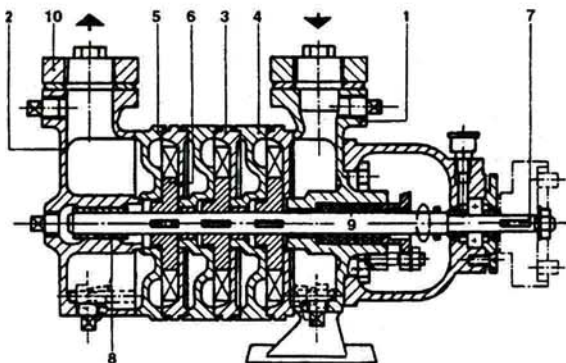

1	Suction casing	GG25
2	Discharge casing	GG25
3,4,5	Intercasing	GG25
6	Impeller	G-CuSn10Zn
7	Shaft	X20Cr13
8	Bearing bush	SF-1S
9	Packing	Special asbestos
10	Flange	GG25



NOWA®

VORTEX PUMPS

Segmental type, self-priming Made by Germany Technique

40HV...65HV.

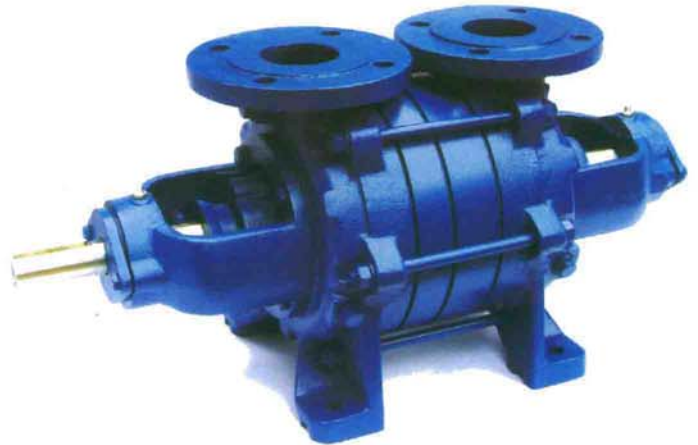
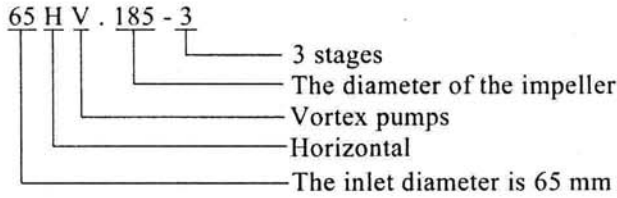

Description

NOWA vortex pumps are horizontal, multistage, self-priming pumps. They are suitable for handling pure and turbid liquids without any abrasives. They can handle gas during normal liquid duty. The pumps are normally driven by electric motors. Other drives are permissible except belt-drive.

Application

NOWA vortex pumps are used:

in all branches of trade and industry – for boosting pressures, for providing cooling water, for circulating water, for feeding boilers, for conveying condensate and for running mix or cleaning plants:

in domestic plants and agriculture – handling water for irrigation, drainage and sprinkling.

Technical Data

Capacity:	Max. 35 m ³ /h
Head:	Max. 133 m
Speed:	Max. 1800 rpm
Temperature:	Max. 120°C
Pump pressure:	PN 16
Shaft sealing:	Stuffing box
Direction of rotation:	Clockwise when looking at the pump from the drive end

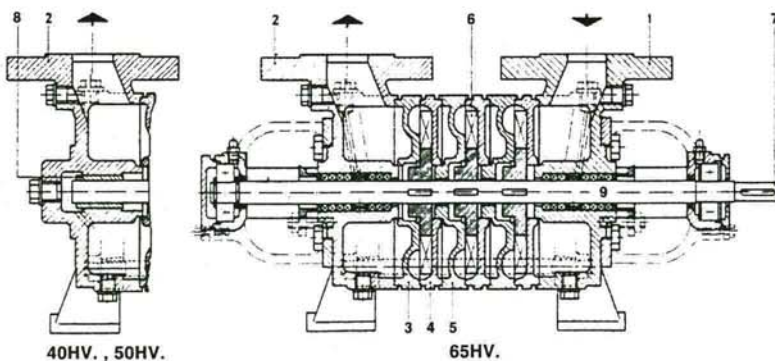

1	Suction casing	GG25
2	Discharge casing	GG25
3,4,5	Intercasing	GG25
6	Impeller	G-CuSn10Zn
7	Shaft	X20Cr13
8	Bearing bush	SF-1S
9	Packing	Special asbestos

Performance Curves

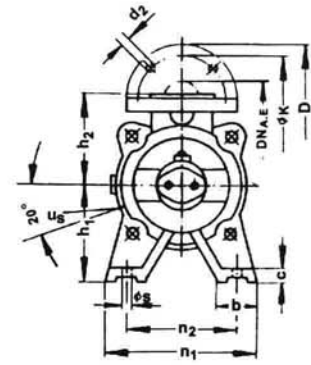
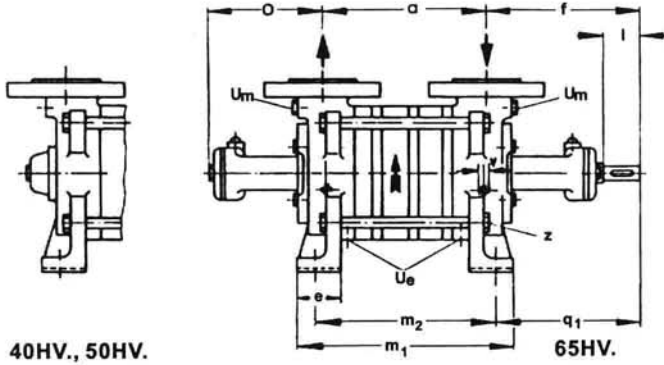
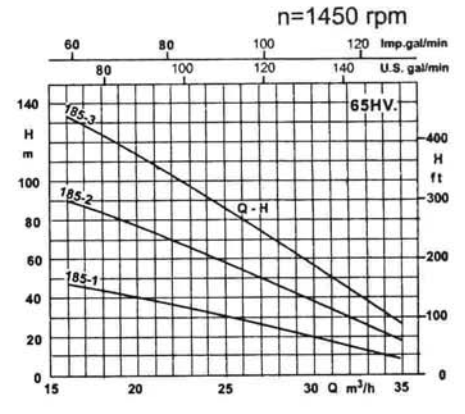
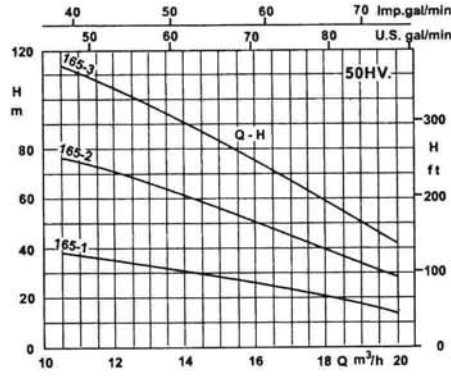
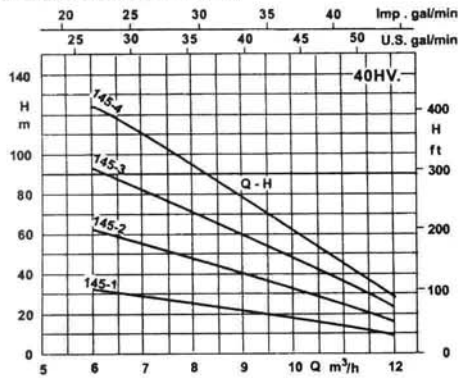

Type of Pump	DN _{A,E}	a	m ₁	m ₂	f	h ₁	h ₂	o	z	b	c	e	n ₁	n ₂	s	q ₁	l	D	k	d ₂ × number
40HV.145-1	40	155	195	159	205	132	132	-	4	47	20	55	218	160	13	203	45	150	110	18×4
40HV.145-2		210	250	214																
40HV.145-3		265	305	269																
40HV.145-4		320	360	324																
50HV.165-1	50	170	220	185	217	150	140	-	6	50	65	250	200	15	234	65	185	145		
50HV.165-2		245	295	260																
50HV.165-3		320	370	335																
65HV.185-1	65	190	276	220	251	150	188	6	50	65	250	200	15	234	65	185	145			
65HV.185-2		280	366	310																
65HV.185-3		370	456	400																

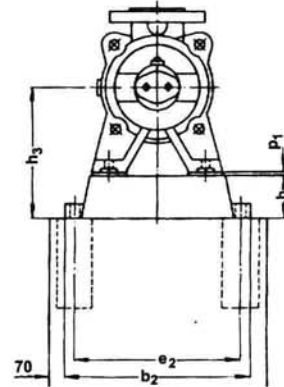
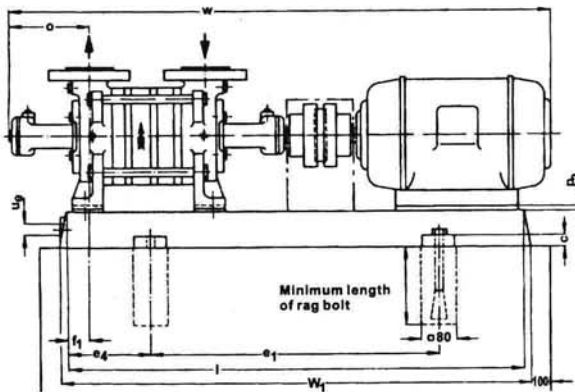

Type of Pump	Motor		Weight		b ₂	c	e ₁	e ₂	e ₄	f ₁	h	h ₃	l	p ₁	p ₂	w	w ₁	u _e	Rag bolt DIN 529
	type	kW	pump	unit															
40HV.145-1	100L-4	2.2	28	76	330	25	480	290	115	42	65	197	710	-	32	-	730	R ^{1/2}	M16×200
40HV.145-2	112M-4	4.0	34	105	360		540	320	130	52			800		820				
40HV.145-3	132S-4	5.5	40	143	390		600	350	150				900		920				
40HV.145-4	132M-4	7.5	45	171	450	30	660	400	170	58	80	212	1000	-	38	1020	M20×200		
50HV.165-1	112M-4	4.0	36	107	360	25	540	320	130		65	215	800		820				
50HV.165-2	160M-4	11.0	46	216	450	30	660	400	170	38	80	240	1000	10	-	1020	M20×200		
50HV.165-3	160L-4	15.0	55	283	490	36	740	440	190	58	110	270	1120	10	-	1140			
65HV.185-1	132M-4	7.5	54	167	390	25	600	350	150	63	65	215	900	-	18	1136	920		M16×200
65HV.185-2	160L-4	15.0	65	293	490	36	740	440	190	73	110	270	1120	10	-	1397	1140		
65HV.185-3	180L-4	22.0	76	337	540	30	840	490	205	53	80	260	1250	30	-	1552	1270		M20×200

Performance graph

$n = 1450 \text{ rpm}$

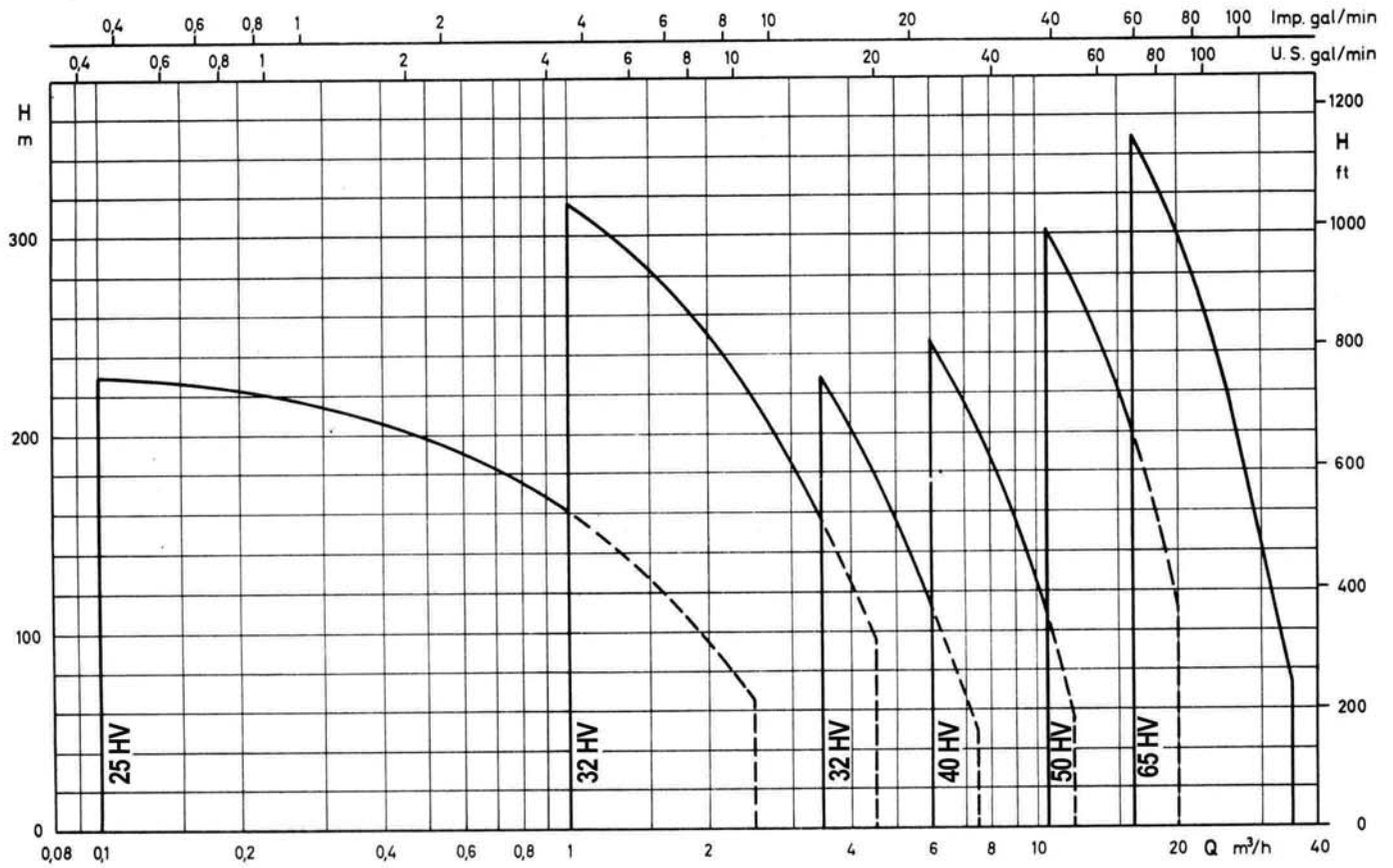

Characteristic curves

$n = 1450 \text{ rpm}$

The following tolerances are applicable for the values indicated in the characteristic curve sheets

design tolerances: output $\pm 5\%$, delivery head¹⁾ $\pm 5\%$
power absorbed + 10%
measuring tolerances: to DIN 1944

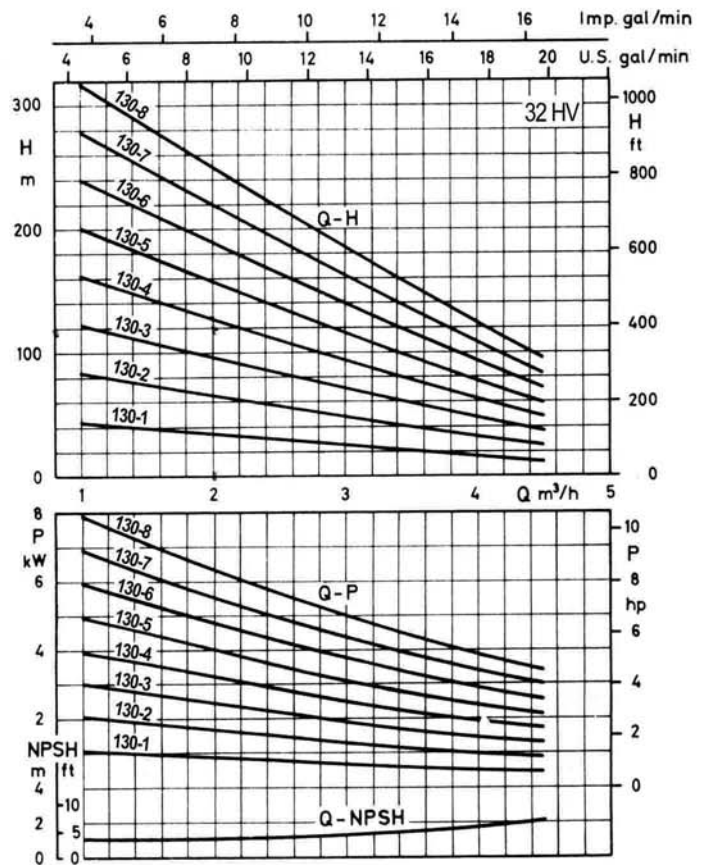
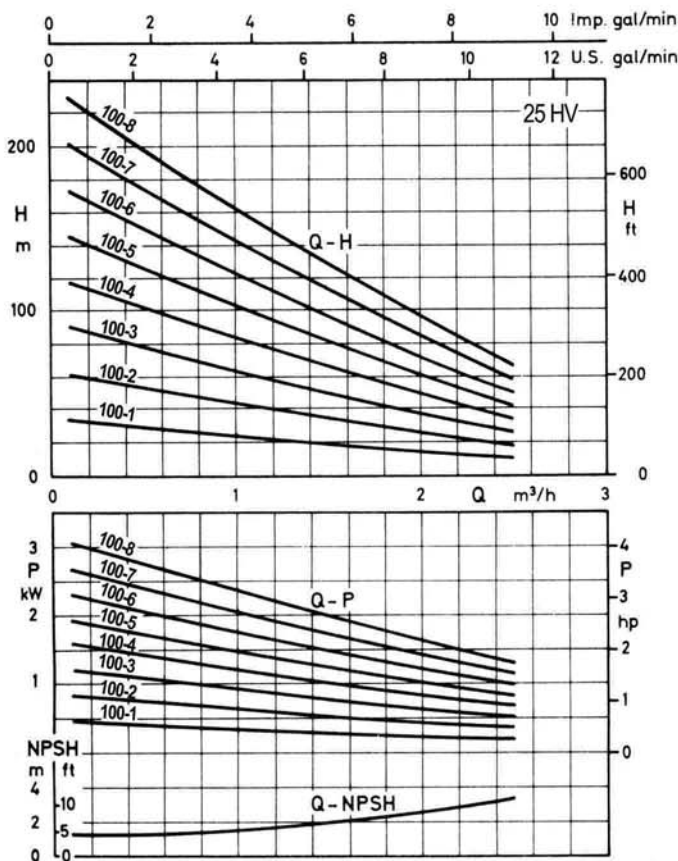

Characteristic curves

$n = 1450 \text{ rpm}$

The following tolerances are applicable for the values indicated in the characteristic curve sheets

design tolerances: output $\pm 5\%$, delivery head¹⁾ $\pm 5\%$
 power absorbed $+ 10\%$
 measuring tolerances: to DIN 1944

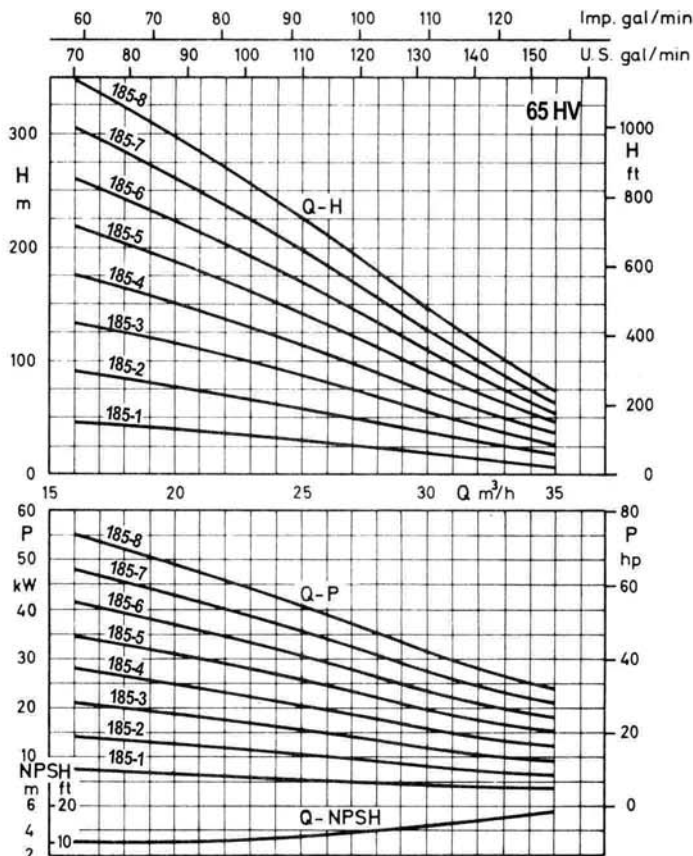
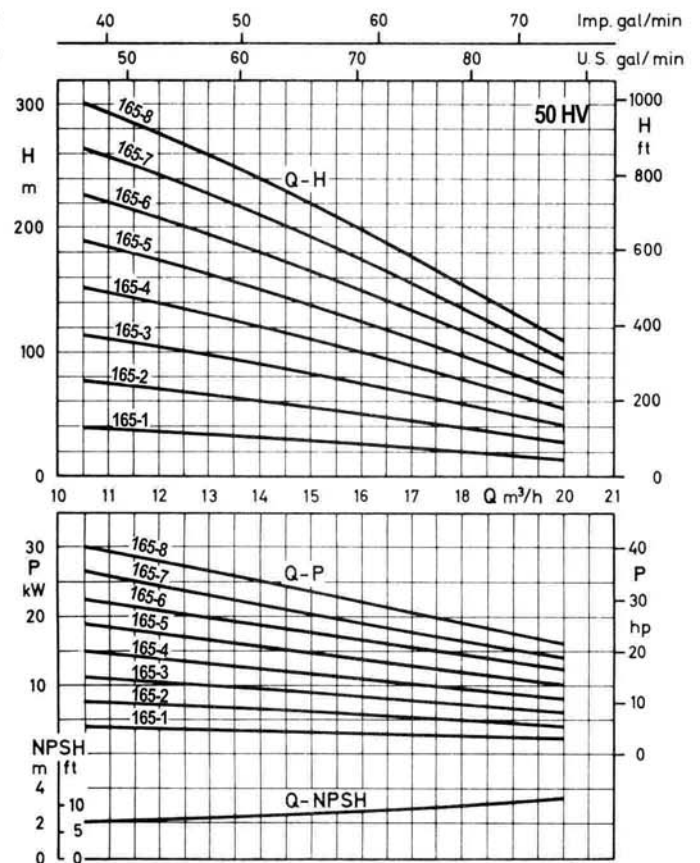
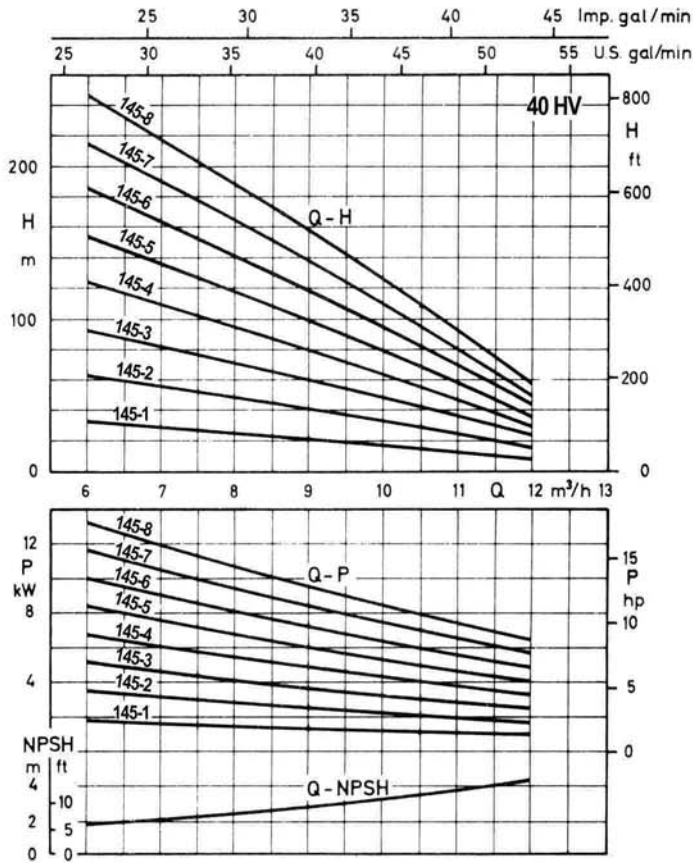

Values are applicable for water $\rho = 1 \text{ kg/l}$

Dimension table

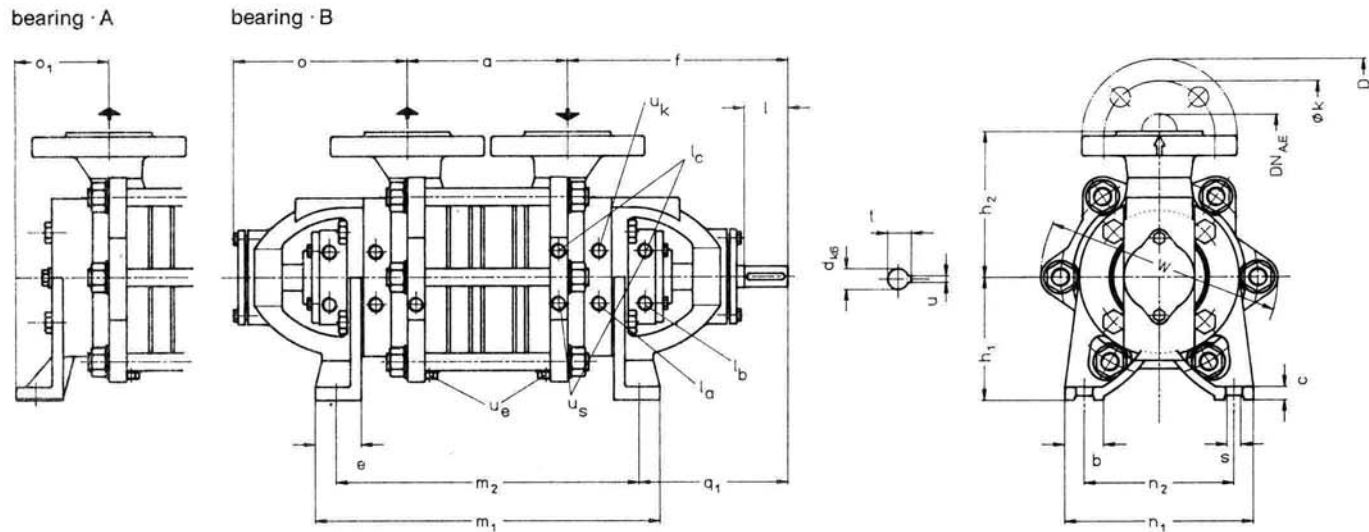

connection sizes: see "v"

- ue = connection for drainage: screwed plug
- uk = connection for cooling liquid for shaft sealing AM1; AN1; AME; ANE; 501
- us = connection for sealing liquid for shaft sealing NAN; NBN; NAC; NBC
- ia = bypass line for shaft sealing 061
- ib = bypass line for bearing · B and shaft sealing AM1; AN1; AME; ANE
- lc = bypass line for bearing · A and shaft sealing AME

size	DN _{A,E}	f	h ₁	h ₂	o	o ₁	o ₂	r	v	w	z	b	c	e	n ₁	n ₂	q ₁	s	d	l	t	u	
25 HV	20	171	100	100	144	60	-	42	R 1/4	-	4	35	10	41	140	105	113	13	14	25	16,1	5	
32 HV	32	201	112	132	158	80		48		214	6		12	42	170	135	134		19	40	21,5	6	
40 HV	40	195	132	140	147	85		50		236	6		40	15	43	195	155		140	24	45	26,9	8
50 HV	50	237	160	165	183	93		58		274	6		45	18	66	215	170		159	15	28	50	
65 HV	65	262	180	180	192	-		118		62	R 3/8		299	6	50	20	63		245	195	172	15	32

size	···01			···02			···03			···04			···05			···06			···07			···08		
	a	m ₁	m ₂	a	m ₁	m ₂	a	m ₁	m ₂	a	m ₁	m ₂	a	m ₁	m ₂	a	m ₁	m ₂	a	m ₁	m ₂	a	m ₁	m ₂
25 HV.100-	120	270	236	120	270	236	154	304	270	188	338	304	222	372	338	256	406	372	290	440	406	324	474	440
32 HV.130-	146	314	280	146	314	280	166	354	320	226	394	360	266	434	400	306	474	440	346	514	480	386	554	520
40 HV.145-	160	303	269	215	358	324	270	413	379	325	468	434	380	523	489	435	578	544	490	633	599	545	688	654
50 HV.165-	175	369	331	250	444	406	325	519	481	400	594	556	475	669	631	550	744	706	625	819	781	700	894	856
65 HV.185-	195	412	374	285	502	464	375	592	554	465	682	644	555	772	734	645	862	824	735	952	914	825	1042	1004

flange connections to DIN 2501 PN 40					
DN _{A,E}	20	32	40	50	65
k	75	100	110	125	145
D	105 (115)	140	150 (154)	165	185 (190)
d ₂ x qty	14 x 4	18 x 4	18 x 4	18 x 4	18 x 8

() as per ANSI

Foundation plan

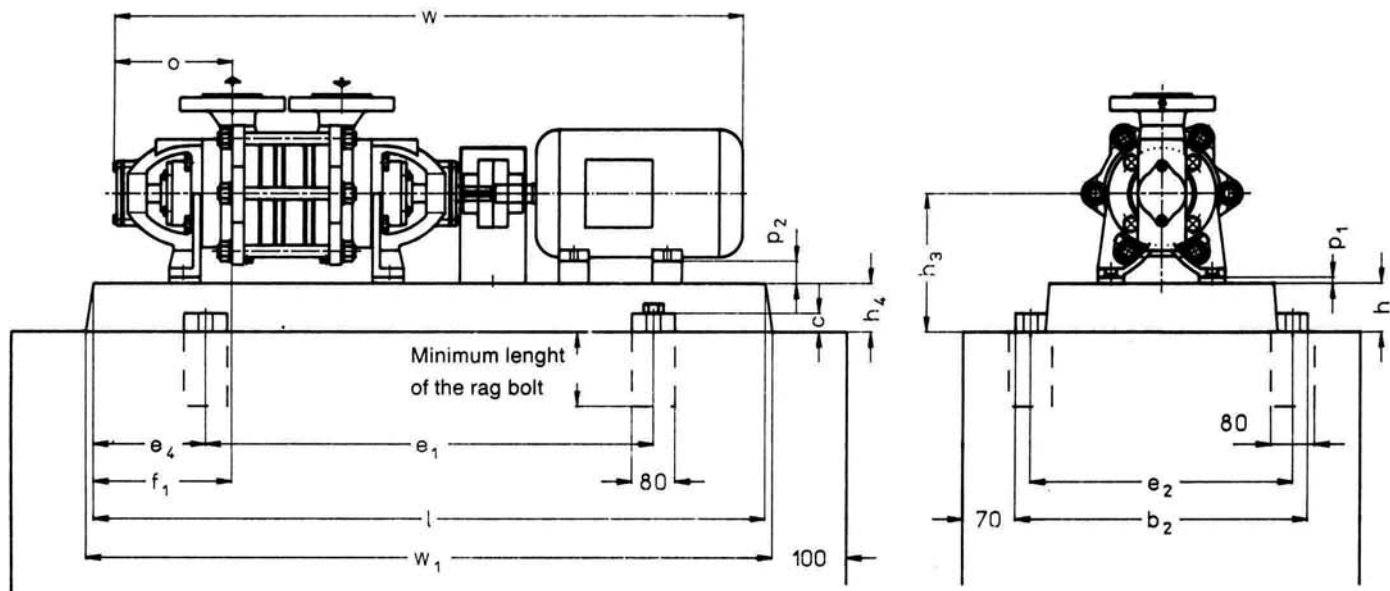

Dimensions in mm, tolerances as per DIN 1686/GTB 17, (base plates) for castings, for stainless steel as per DIN 1683 GTB 16/5, for welded parts as per DIN 8570 B

n = 1450 rpm

size	motor		baseplate 271...100	coup- ling	weight BN		b ₂	c	e ₁	e ₂	e ₄	f ₁	h/h ₄	h ₃	l	o	p ₁	p ₂	AB w*	w ₁	u _e	rag bolt DIN 529																		
	size	kW			Pump kg	unit kg																																		
25 HV.100-1	71 b	0,37	210	A 10	20	45	300		420	260	105	108		630				29	673	650																				
	80 a	0,55			21	49												98	20				682																	
25 HV.100-2	80 b	0,75			241	A 10												23	52				330		480	290	115	78	710					10	682	730				
	90 S	1,1																25	59															98	20				697	
25 HV.100-3	90 L	1,5			272	A 25												25	61				360		540	320	130	88	800					10	731	820				
	100 L	2,2																26	65															98	10				776	
25 HV.100-4	90 S	1,1			241	A 10												26	62				330		480	290	115	78	165	710	144				10	805	730			
	90 L	1,5																27	70																98	10				839
25 HV.100-5	100 L	2,2			272	A 25												27	77				360		540	320	130	88	800						10	889	820			
	100 L	3,0																28	72																98	10				923
25 HV.100-6	90 L	1,5	303	A 10	28	72	390	25	600	350	150	88	65	900					10	898	920	R 1/2	M 16 x 200																	
	100 L	2,2			30	90													98	10				957																
25 HV.100-7	100 L	3,0	303	A 25	30	92	390		600	350	150	128		900					10	991	920	R 1/2	M 16 x 200																	
	100 L	3,0			33	95													98	10				991																
25 HV.100-8	100 L	3,0	303	A 25	33	95	390		600	350	150	88		900					10	1025	920	R 1/2	M 16 x 200																	
	100 L	3,0			33	96													98	10				1025																
32 HV.130-1	80 b	0,75	241	A 10	32	64	330		480	290	115	117		710					32	767	730																			
	90 S	1,1			34	70													107	22				807																
32 HV.130-2	90 L	1,5			272	A 25													34	74				360		540	320	130	107	177	800					12	832	820		
	100 L	2,2																	38	74																127	12			
32 HV.130-3	100 L	2,2			272	A 25													38	89				360		540	320	130	97	177	800					12	931	820		
	100 L	3,0																	41	90																97	12			
32 HV.130-4	100 L	2,2			303	A 63													41	103				390		600	350	150	127		900					12	971	920		
	112 M	4,0																	45	104																127	12			
32 HV.130-5	100 L	3,0			303	A 25													45	108				390		600	350	150	107		900					12	1011	920		
	112 M	4,0																	45	126																137	12			
32 HV.130-6	132 S	5,5	344	A 63	48	142	450	30	660	400	170	137	80	1000					20	1094	1020																			
	132 M	7,5			48	164													137	20				1094																
32 HV.130-7	112 M	4,0	344	A 63	52	147	450	30	660	400	170	117		1000					20	1172	1020																			
	132 S	5,5			52	174													137	20				1172																
32 HV.130-8	132 M	7,5	0110.00.385	A 100	56	209	490	40	740	440	190	137	110	242	1120				20	1212	1270	R 1/2	M 20 x 200																	
	160 M	11,0			56	219													137	20				1212																
			436	A 100	56	255	540	30	840	490	205	137	80	240	1250			48	1379	1270	R 1/2																			

Foundation plan

n = 1450 rpm

size	motor		baseplate 271... .100	coup- ling	weight BN		b ₂	c	e ₁	e ₂	e ₄	f ₁	h/h ₄	h ₃	l	o	p ₁	p ₂	AB w*	w ₁	u _e	rag bolt DIN 529	
	size	kW			Pump kg	unit kg																	
40 HV.145-1	90 L 100 L	1,5 2,2	241	A 10	43	84 95	330		480	290	115	84 114			710			42	829 888	730		M 16 x 200	
40 HV.145-2	100 L 100 L 112 M	2,2 3,0 4,0	272	A 25	49	101 102 120	360	25	540	320	130	84 84 74	65	197	800			32	943 943 943	820	R 1/2		
40 HV.145-3	112 M 132 S	4,0 5,5	303	A 63	56	138 162	390		600	350	150	104 84			900			20	998 1081	920			
40 HV.145-4	132 S 132 M	5,5 7,5	344	A 63	62	178 188	450	30	660	400	170	104 84	80	212	1000	147			1136 1174	1020			
40 HV.145-5	132 S 132 M 160 M	5,5 7,5 11,0	0110.00.385	A 100	68	184 231 275	490	40	740	440	190	74 94 74	110	242	1120		28		1191 1229 1356			M 20 x 200	
40 HV.145-6	132 M 160 M	7,5 11,0	436	A 63	74	237 272	540	30	840	490	205	94	80	212	1250			28	1284	1270	R 1/2		
40 HV.145-7	132 M 160 M 160 L	7,5 11,0 15,0		A 100	80	234 278 314						124 84 154							240				1411
40 HV.145-8	160 M 160 L	11,0 15,0	0110.00.487	A 100	86	298 319	610	40	940	550	230	144 114	100	260	1400		28		1521 1565			M 24 x 250	
50 HV.165-1	100 L 112 M	3,0 4,0	303	A 25	60	124 143	390	25	600	350	150	148 138	65	225	900			60 48	981 981	920	R 1/2	M 16 x 200	
50 HV.165-2	132 S 132 M 160 M	5,5 7,5 11,0	344	A 63	71	187 197 278	450	30	660	400	170	138 108 148	80	240	1000			28	1139 1177 1304	1020		M 20 x 200	
50 HV.165-3	132 M 160 M 160 L	7,5 11,0 15,0	0110.00.385	A 100	82	245 280 298	490	40	740	440	190	148 158 138	110	270	1120			28	1252 1379 1423				
50 HV.165-4	160 M 160 L	11,0 15,0	436	A 100	92	290 325	540	30	840	490	205	128 178	80	240	1250				1454 1498	1270	R 1/2		
50 HV.165-5	160 L 180 M 180 L	15,0 18,5 22,0	0110.00.487	A 160	103	336 357 377	610	40	940	550	230	148 138 118			1400	183	20		1573 1600 1638			M 24 x 250	
50 HV.165-6	160 L 180 M 180 L 200 L	15,0 18,5 22,0 30,0	538	A 100	114	387 408 428 509	660	35	1060	600	270	188 188 168 148	100	280	1600			20	1648 1675 1713 1773	1620	R 1/2		
50 HV.165-7	180 M 180 L 200 L	18,5 22,0 30,0		A 160		125						419 439 520	148 138 108	280	20	1750 1788 1848							
50 HV.165-8	180 L 200 L	22,0 30,0	9110.177.01	A 250	136	452 533	530		970	470	400	183 183	180/ 160	340 360	1770			20	1863 1923			M 16 x 200	
65 HV.185-1	132 S 132 M	5,5 7,5	344	A 63	84	201 221	450	30	660	400	170	159 139	80	260	1000			48	1118 1156	1020	R 1/2	M 20 x 200	
65 HV.185-2	160 M 160 L	11,0 15,0	0110.00.385	A 100	97	305 317	490	40	740	440	190	119 149	110	290	1120			20	1373 1417	1270	R 1/2		
65 HV.185-3	180 M 180 L	18,5 22,0	0110.00.487	A 160	109	363 383	610	40	940	550	230	189 169		280	1400					1534 1572			M 24 x 250
65 HV.185-4	180 L 200 L	22,0 30,0	538	A 250	122	396 517	660	35	1060	600	270	119 189	100	300	1600			20	1662 1722	1620	R 1/2		
65 HV.185-5	200 L 225 S	30,0 37,0		A 250	134	529 598						149 119	325	45	1812 1822								
65 HV.185-6	200 L 225 S 225 M	30,0 37,0 45,0	9110.177.01	PKZ 20	147	544 612 675	530		970	470		194 194 194	180/ 160	360 385	1770			25	1902 1912 1937			M 16 x 200	
65 HV.185-7	200 L 225 S 225 M 250 M	30,0 37,0 45,0 55,0	9110.198.03	A 250	159	556 644 707 790	630		1180	570	400	129 264 264 239	205/ 160	360 385	1980			25	1992 2002 2027 2135				
65 HV.185-8	225 S 225 M 250 M	37,0 45,0 55,0		PKZ 20		172						657 720 801	174 174 149	385	25	2092 1307 2225							

